

INSTRUCTION MANUAL

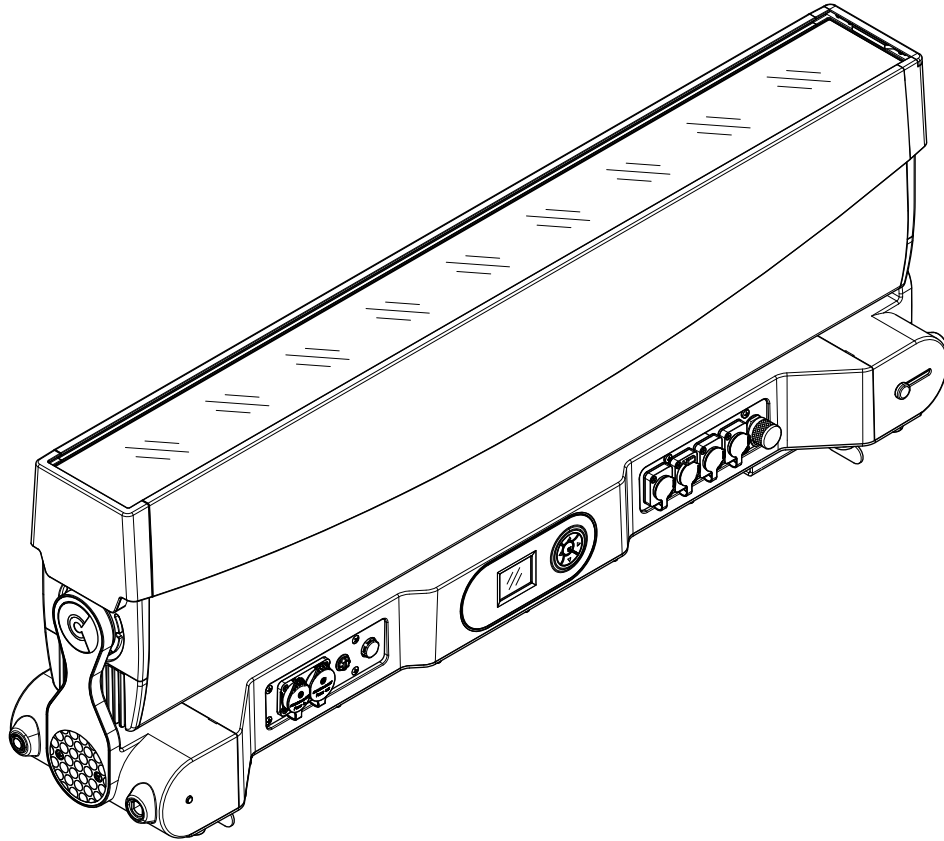

INDEX

Page	Contents
2	1. Safety information
3	2. Unpacking and preparation
3	3 Installation and start-up
3	3.1 Fixture overview
4	3.2 Installing the fixture
6	3.3 Connecting to mains supply
6	3.4 Connecting the control signal line: DMX / Art-Net
7	3.5 Switching on the fixture and basic SetUp
8	4. Maintenance
8	4.1 Fuses replacing
9	4.2 Periodical cleaning & Caution
10	4.3 Battery removal
11	5. Dimensions
11	6. Cause and solution of problems

Congratulations on choosing a Claypaky product!

We thank you for your custom.

Please note that this product, as all the others in the rich Claypaky range, has been designed and made with total quality to ensure excellent performance and best meet your expectations and requirements.

1. SAFETY INFORMATION

EN

SAFETY INFORMATION

IMPORTANT: Claypaky recommends you carefully read and keep the safety information on this product, also available in digital format at the following link:

www.claypaky.com

Ref: FIS02F - Safety Information Volero Batten Aqua

IT

INFORMAZIONI DI SICUREZZA

IMPORTANTE: Claypaky raccomanda di leggere accuratamente e conservare le informazioni di sicurezza relative a questo prodotto, sempre reperibili in versione digitale al seguente link:

www.claypaky.com

Rif: FIS02F - Safety Information Volero Batten Aqua

DE

INFORMATIONEN ZUR SICHERHEIT

WICHTIG: Claypaky empfiehlt, die Sicherheitsinformationen bezüglich dieses Produkts genau zu lesen und aufzubewahren. Sie sind in Digitalversion immer unter folgendem Link auffindbar:

www.claypaky.com

Ref: FIS02F - Safety Information Volero Batten Aqua

ES

INFORMACIONES DE SEGURIDAD

IMPORTANTE: Claypaky recomienda leer detenidamente y conservar la información de seguridad relativa a este producto. Además, está disponible una versión digital de la misma en el siguiente enlace:

www.claypaky.com

Ref: FIS02F - Safety Information Volero Batten Aqua

FR

CONSIGNES DE SÉCURITÉ

IMPORTANT: Claypaky recommande de lire attentivement et de conserver les informations de sécurité relatives à ce produit, disponibles en version digitale au lien suivant:

www.claypaky.com

Réf. : FIS02F - Safety Information Volero Batten Aqua

RU

ИНСТРУКЦИЮ ПО ТЕХНИКЕ БЕЗОПАСНОСТИ

ВАЖНО: Claypaky рекомендует внимательно прочитать и сохранить инструкцию по технике безопасности данного изделия, которая всегда доступна в электронном формате по следующей ссылке:

www.claypaky.com

Наименование: FIS02F - Safety Information Volero Batten Aqua

2. UNPACKING AND PREPARATION

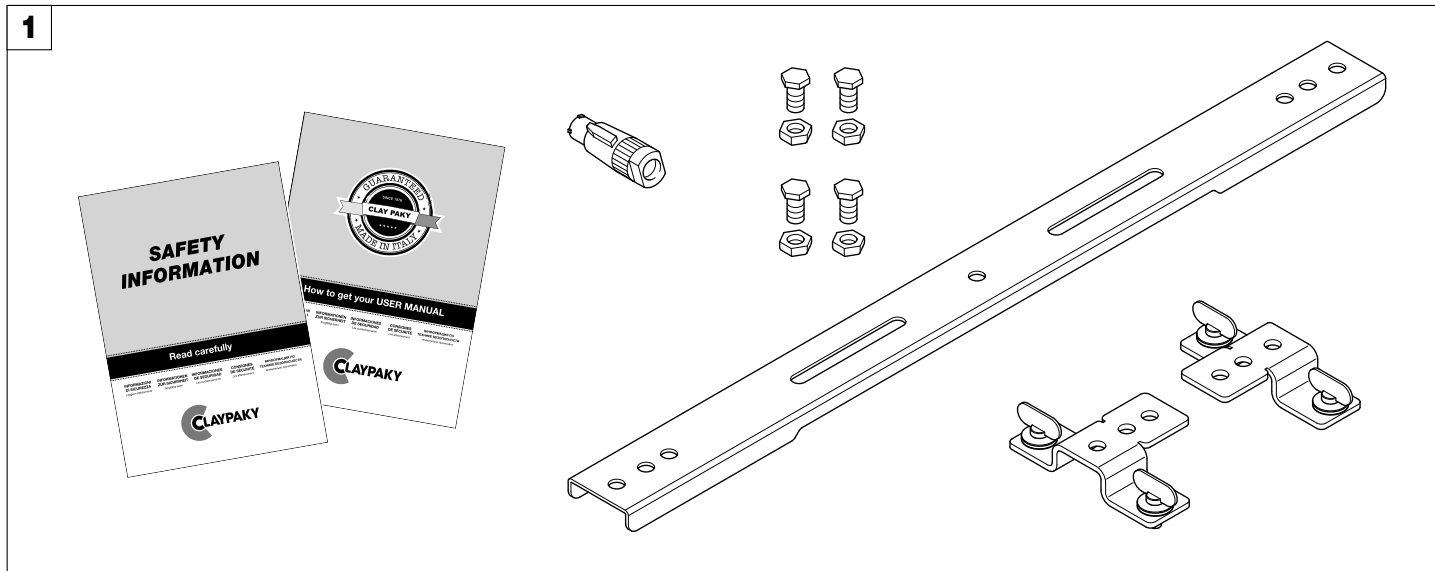

Packing contents - Fig. 1

3. INSTALLATION AND START-UP

3.1 Fixture overview

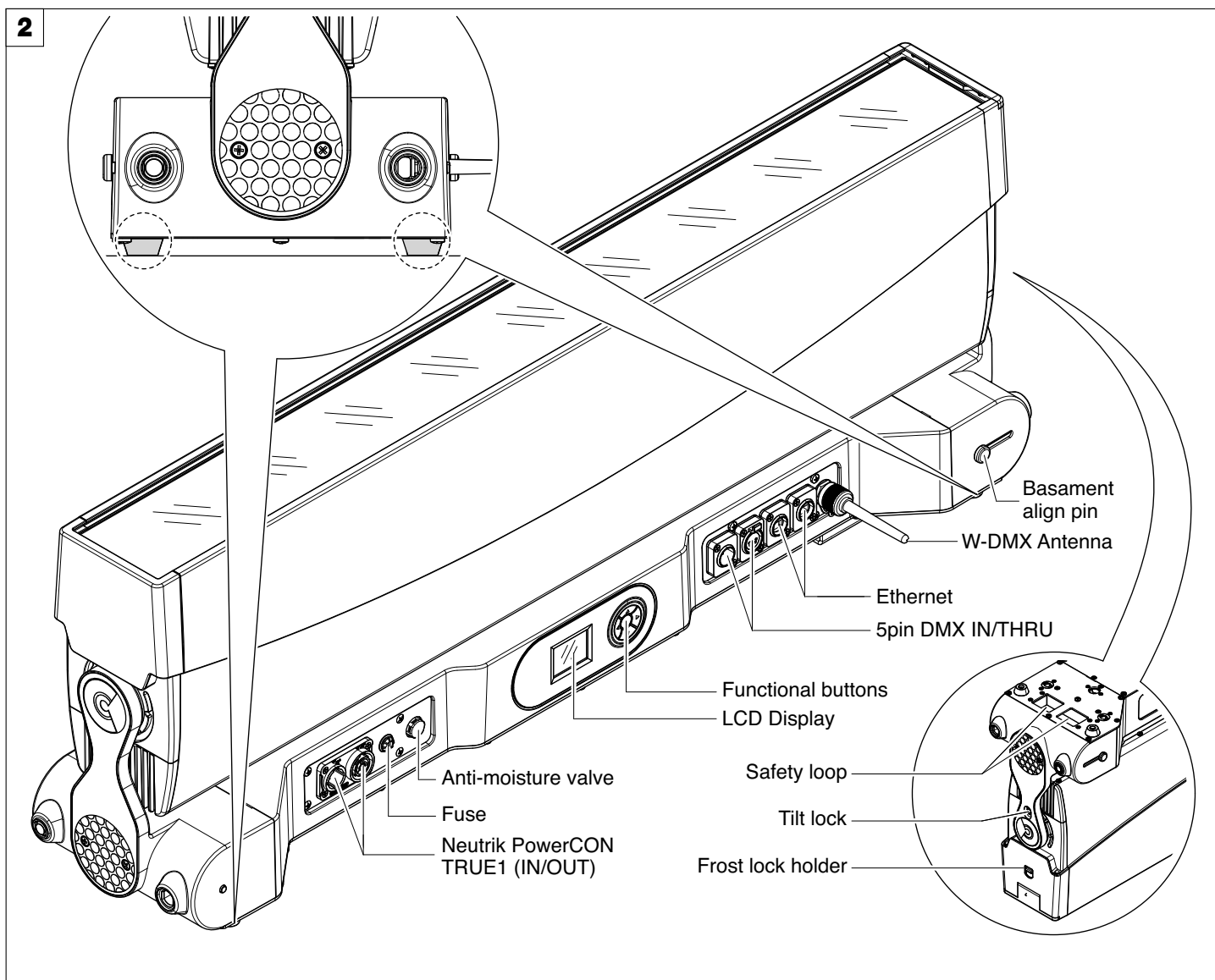

3.2 Installing the fixture

3

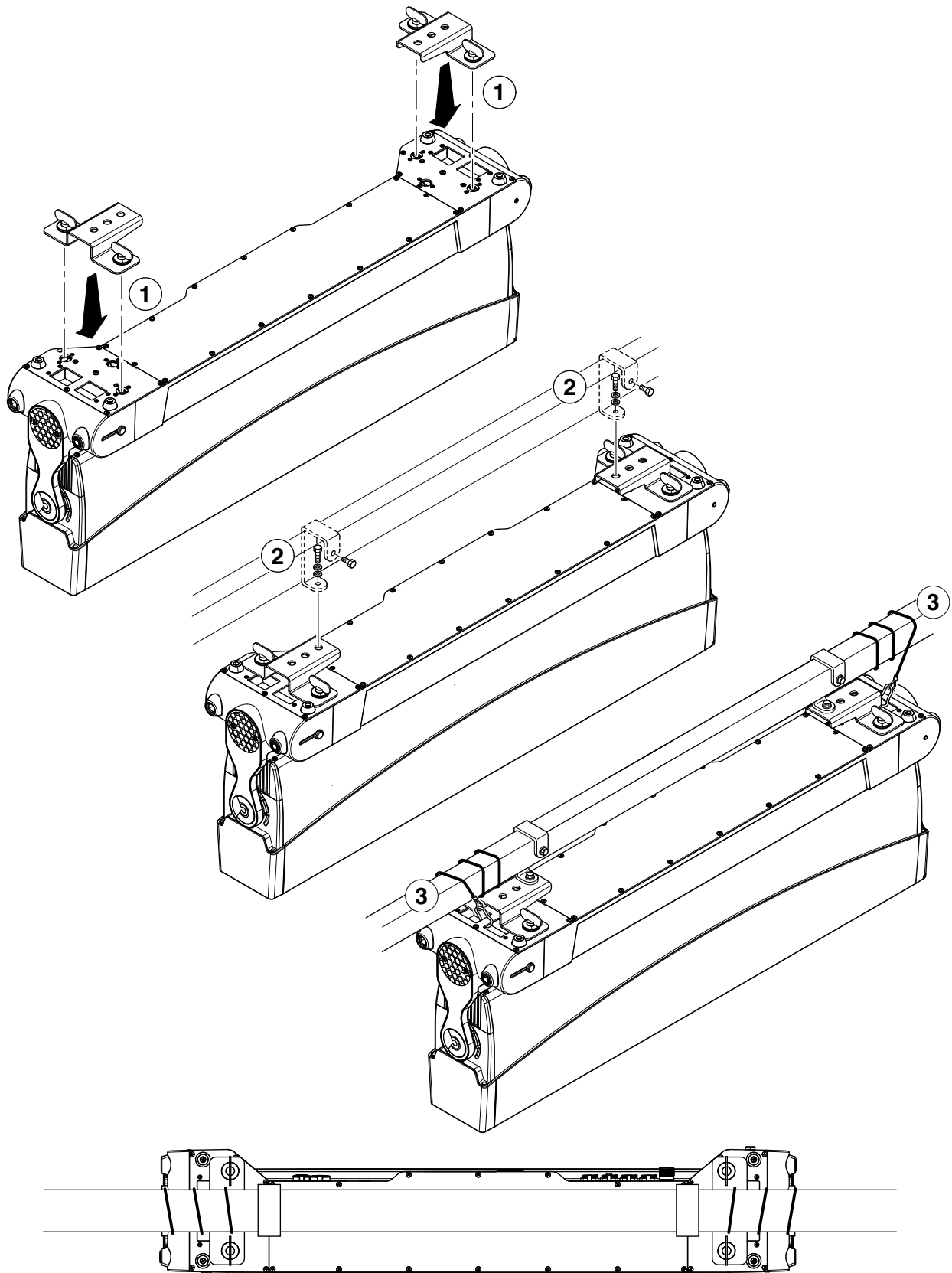

Projector installation - Fig. 3

The projector can be installed on the floor resting on specific rubber feet, on a truss, on the ceiling or wall.

WARNING: the safety chains must be installed except when the projector rests on the floor. (Code 2x 105041/801 available upon request). This must be secured to the projector support structure and then hooked to the two fastening points.

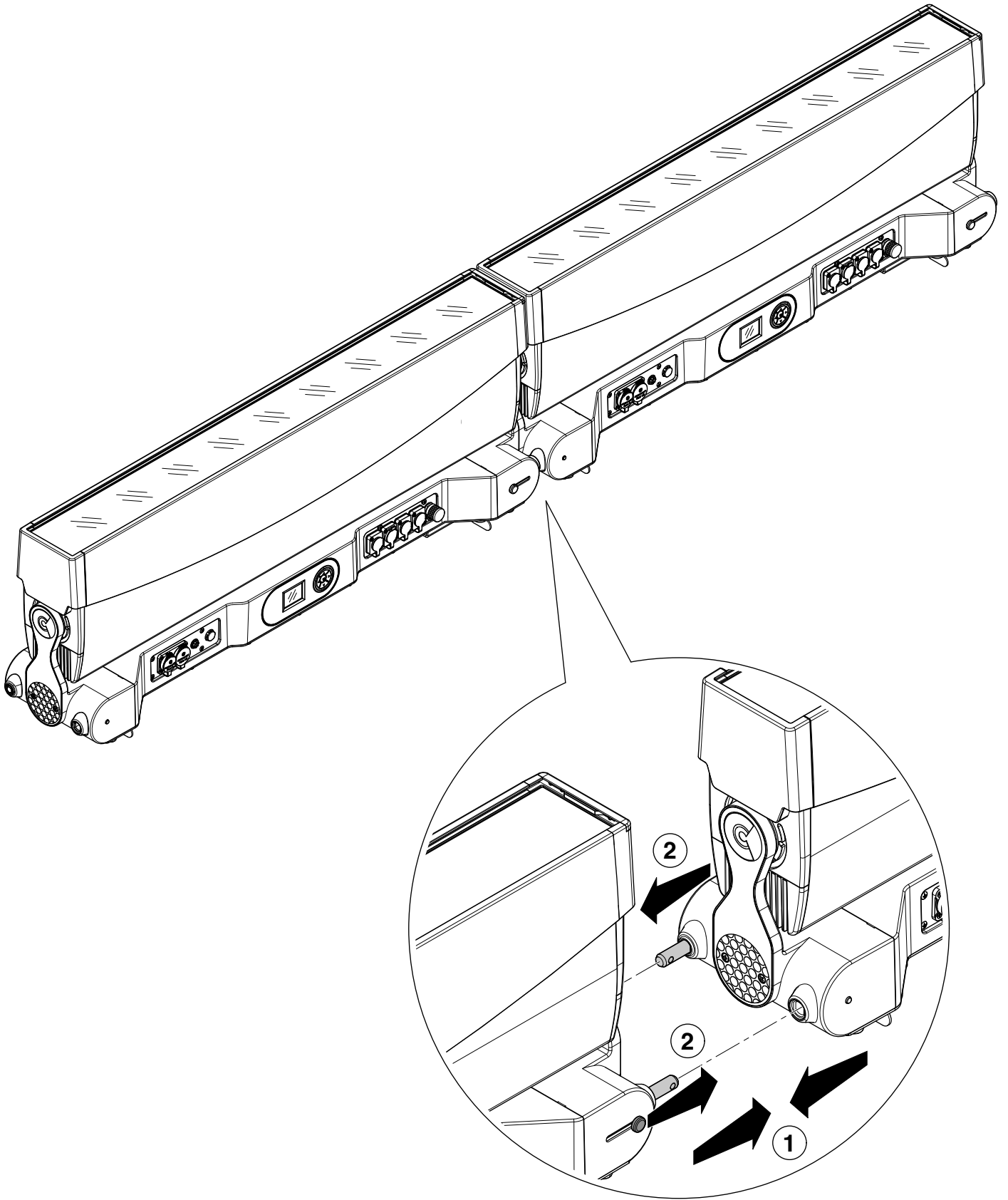

Floor Line array connection - Fig. 4

3.3 Connecting to mains supply

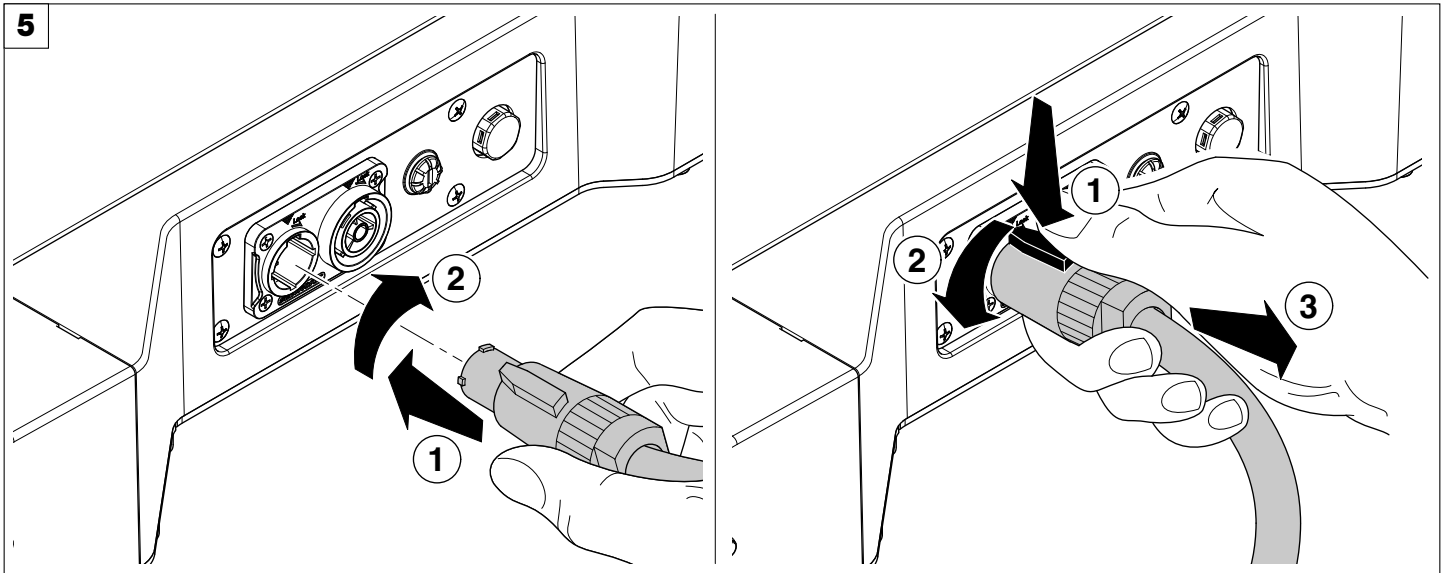

Connecting and disconnecting the power cord - Fig. 5

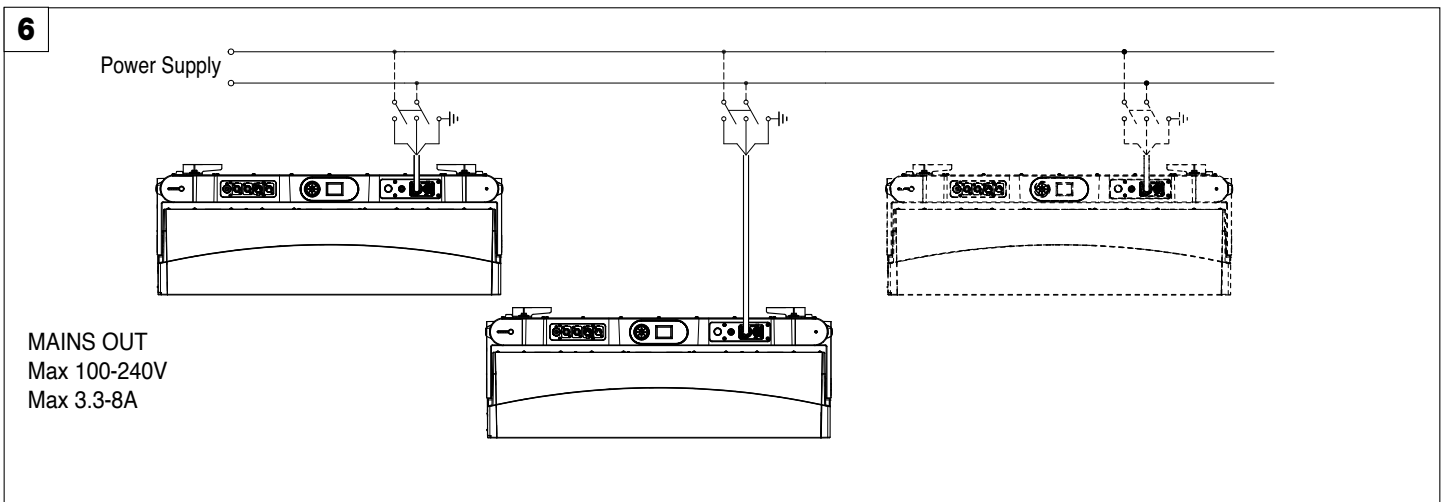

Connections to the power mains - Fig. 6

3.4 Connecting the control signal line: DMX / Art-Net

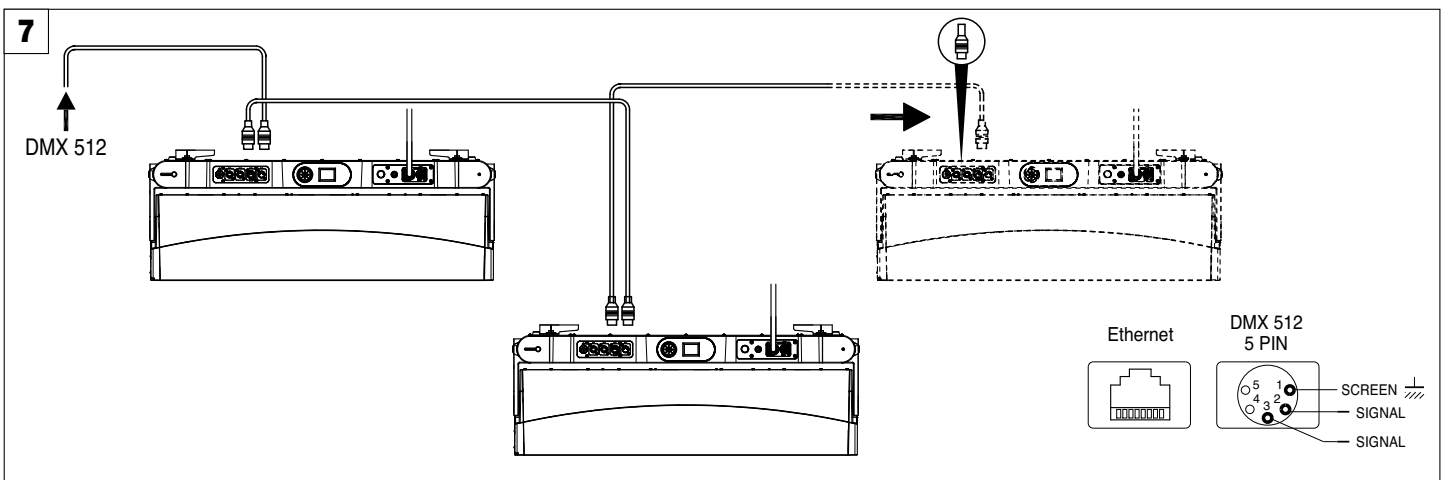

Connections to the control signal line (DMX) - Fig. 7

Use a cable conforming to specifications EIA RS-485: 2-pole twisted, shielded, 120Ω characteristic impedance, 22-24 AWG, low capacity. Do not use microphone cable or other cable with characteristics differing from those specified. End connections must be made using XLR type 5-pin male/female connectors. A terminating plug must be inserted in the last projector with a resistance of 120 (minimum 1/4 W) between terminals 2 and 3.

IMPORTANT: The wires must not make contact with each other or with the metal casing of the connectors. The casing must be connected to the shield braid and pin 1 of the connectors.

3.5 Switching on the fixture and basic SetUp

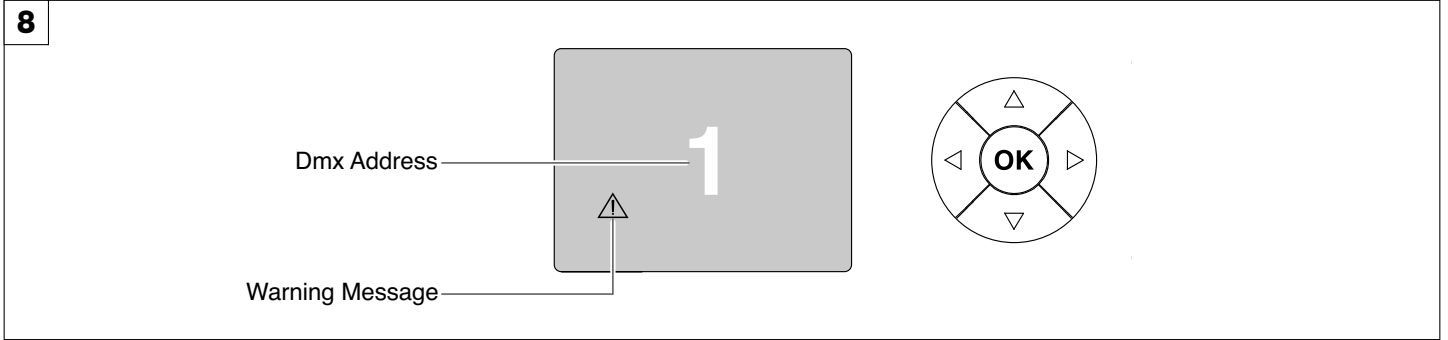

Switching on the projector - Fig. 8

Switch-on the fixture. The projector starts resetting the effects. At the same time, the following information scrolls on the display:



On conclusion of resetting in case of absence of the dmx signal, Tilt move to the "Home" position (Tilt 128 bit). The control panel (Fig. 7) has a display and buttons for the complete programming and management of the projector menu. The display can be in one of two conditions: rest status and setting status. When it is in the rest status, the display shows the projector's DMX address.

During menu setting status, after a wait time (about 30 seconds) without any key having been pressed, the display automatically returns to rest status. It should be noted that when this condition occurs, any possible value that has been modified but not yet confirmed with the **OK** key will be cancelled.

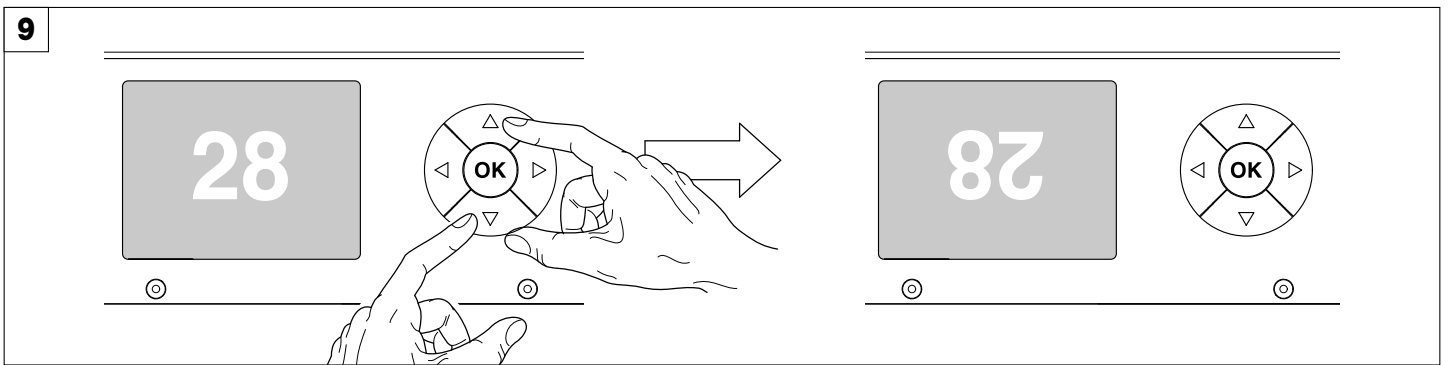

Reversal of the display - Fig. 9

To activate this function, press UP and DOWN keys simultaneously while the display is in the rest mode. This status will be memorised and maintained even for the next time it will be switched on. To return to the initial state, repeat the operation all over again.

Setting the projector starting address







On each projector, the starting address must be set for the control signal (addresses from 1 to 512).

The address can also be set with the projector switched off.

Functions of the buttons - Using the menu

	Confirms the displayed value, or activates the displayed function, or enters the successive menu.
	DOWN Decreases the value displayed (with auto-repetitions) or passes to the next item in the menu.
	UP Increases the value displayed (with auto-repetitions) or passes to the previous item in a menu.
	LEFT Return to the top level.
	RIGHT Commute from units, tens, hundreds, in the "Address", "Fixture ID" and "Calibration" menu.

USING THE MENU:

- 1) Press LEFT  once – “Main Menu” appears on the display.
- 2) Use the UP  and DOWN  keys to select the menu to be used:
 - Setup (Setup Menu): To set the setting options.
 - Option (Option Menu): To set the operating options
 - Informations (Informations Menu): To read the counters, software version and other information.
 - Manual Control (Manual control Menu): To trigger the test and manual control functions.
 - Test (Test Menu): To check the proper functioning of effects
 - Advanced (Advanced Menu): Access to the "Advanced menu" is recommended for a trained technical personnel.
- 3) Press  to display the first item in the selected menu.
- 4) Use the UP  and DOWN  keys to select the MENU items.

Setting addresses and options with the projector disconnected

The projector's DMX address, as well as other possible operating options, can also be set when the appliance is disconnected from the electricity supply. All that is needed is to press RIGHT  to momentarily activate the display and thus access the settings. Once the required operations have been carried out, the display will switch off again after a wait time of 30 seconds.

4. MAINTENANCE

4.1 Fuses replacing

10

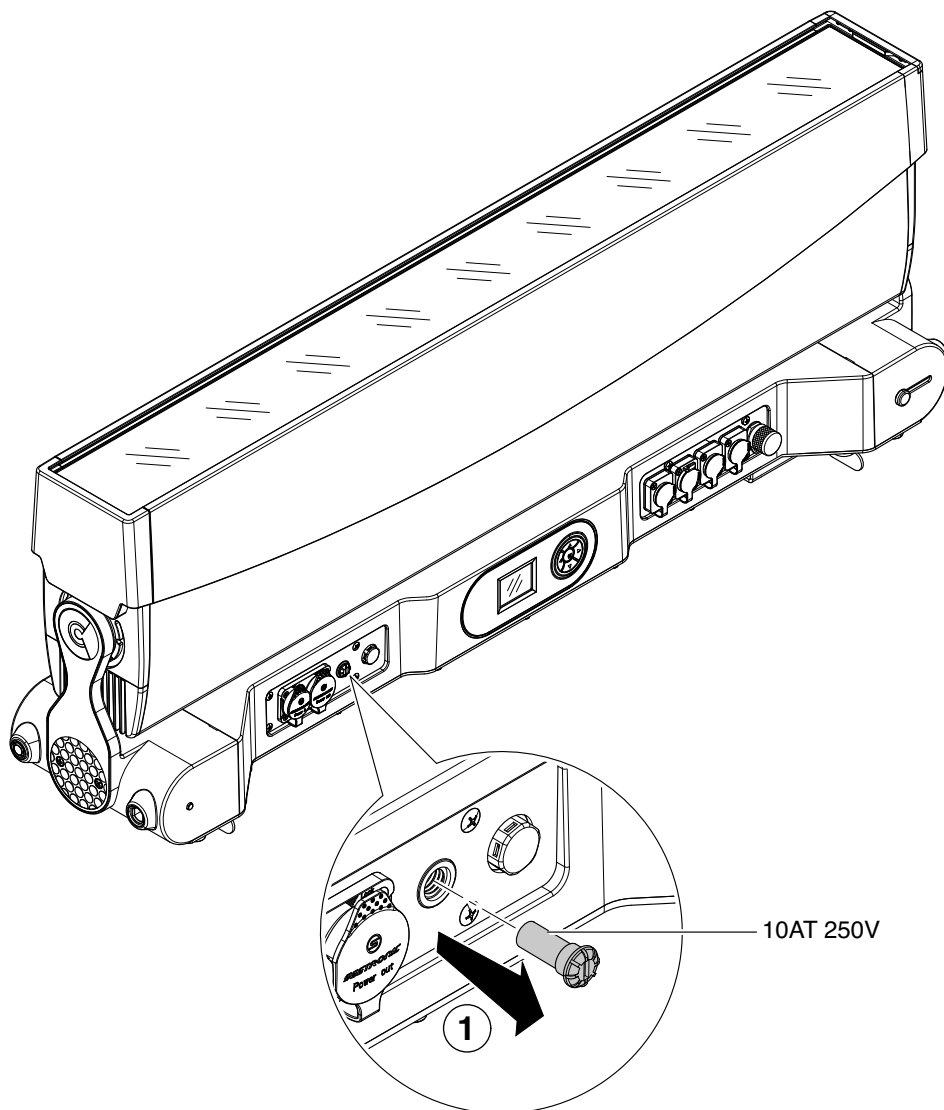

Fuse replacing - Fig. 10

Each Volero Batten Aqua has 1 fuse 10AT 250V, associated with the main power cord connection.

4.2 Periodical cleaning & Caution

11

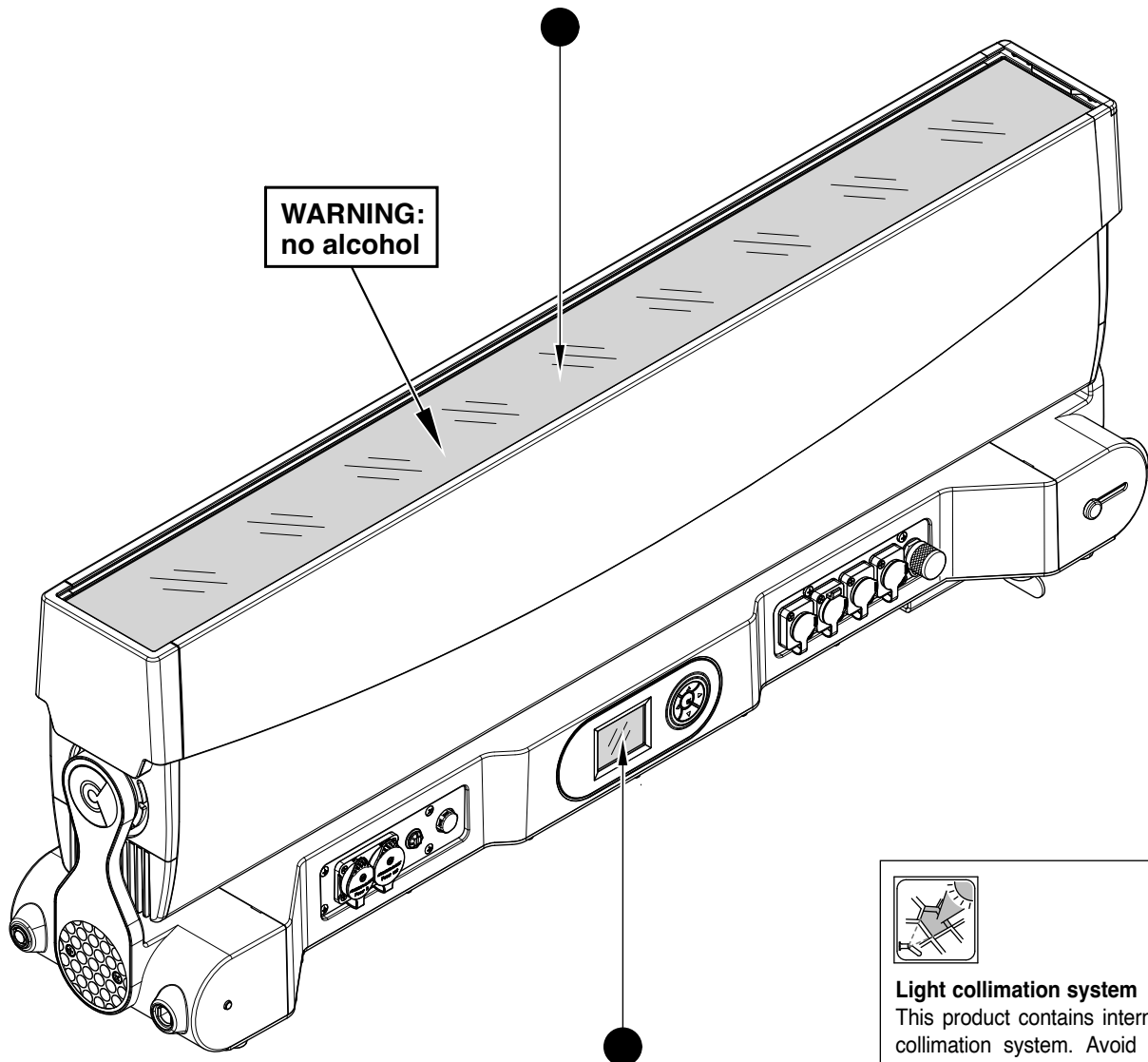

WARNING:
no alcohol



Light collimation system

This product contains internal light collimation system. Avoid intense light from any angle.

● Parts requiring frequent cleaning.

WARNING

- IP66 fixture
 - Failure to completely remove power from fixture prior to servicing can lead to serious injury or death.
- For additional service information please contact service@claypaky.it

IMPORTANT

The screws to be removed have rubber sleeve gaskets at the threaded end of the screw. DO NOT LOOSE these. They must be reinstalled when reassembly is done. If these rubber sleeve gaskets are damaged, they must be replaced with exact original equipment (OE) parts, we also suggest to replace the rubber sleeve gasket every 2 years.

To maintain IP66 rating each cover has rubber gasket on it. If any rubber gasket is lost or damaged, it must be replaced by an original equipment (OE) part. We also suggest to replace the rubber sleeve gasket every 2 years.

CAUTION:

- To ensure optimal operation and performance for a long time it is essential to periodically clean the parts subject to dust and grease deposits. The frequency with which the following operations are to be carried out depends on various factors, such as the amount of the effects and the quality of the working environment (air humidity, presence of dust, salinity, etc.).
It is recommended that the projector undergoes an annual service by a qualified technician for special maintenance involving at least the following operations:
 - General cleaning of internal parts.
 - Restoring lubrication of all parts subject to friction, using lubricants specifically supplied by Claypaky.
 - General visual check of the internal components, cabling, mechanical parts, etc.
 - Electrical, photometric and functional checks; eventual repairs.

Cleaning the lenses

Only use neutral soap and water to clean the lenses, then dry it carefully with a soft, non-abrasive cloth. (WARNING: the use of alcohol or any other detergent could damage the lenses).

4.3 Battery removal

12

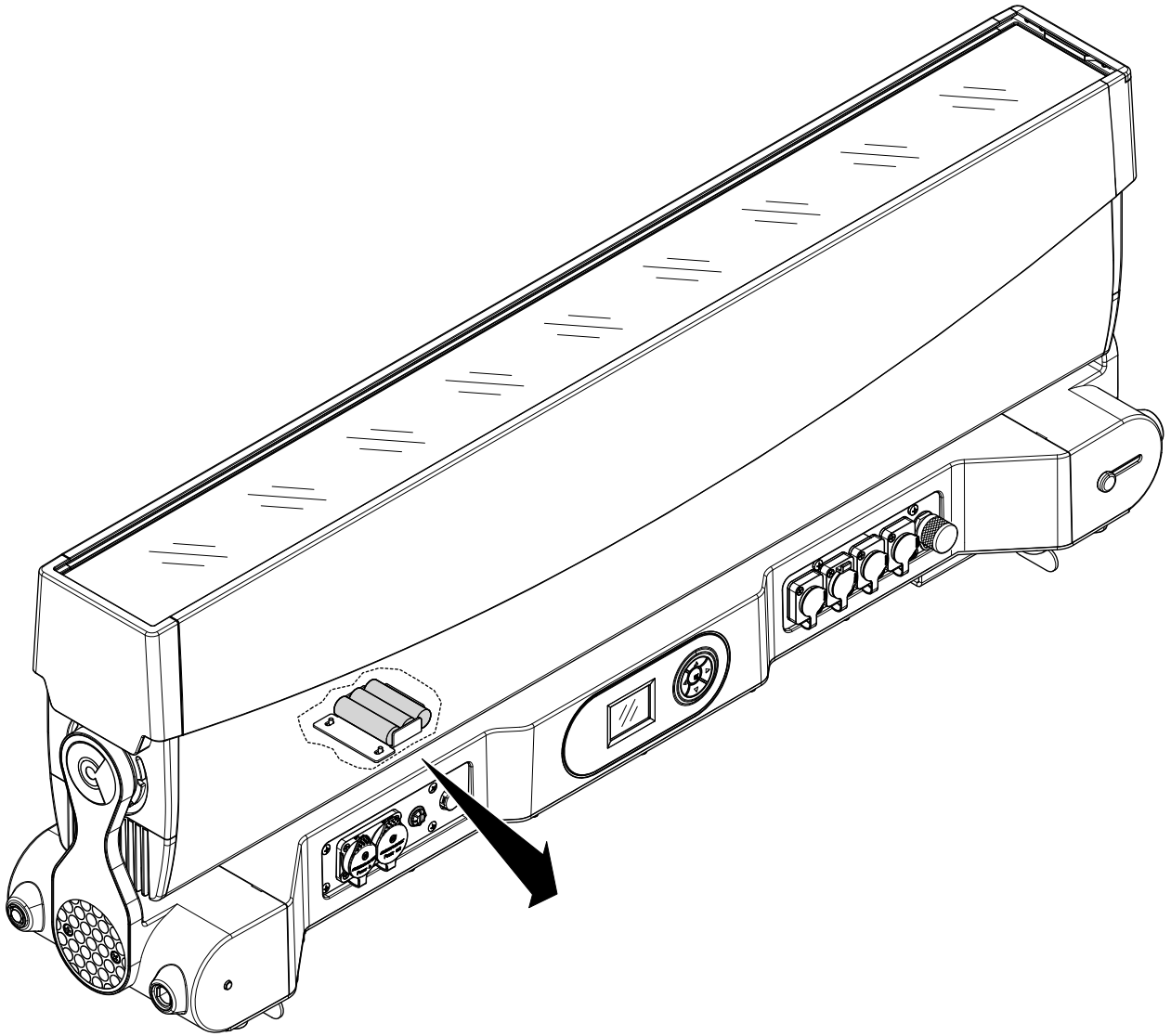

This product contains a rechargeable battery. To preserve the environment, please dispose the battery at the end of its life according to the regulation in force.

5. DIMENSIONS

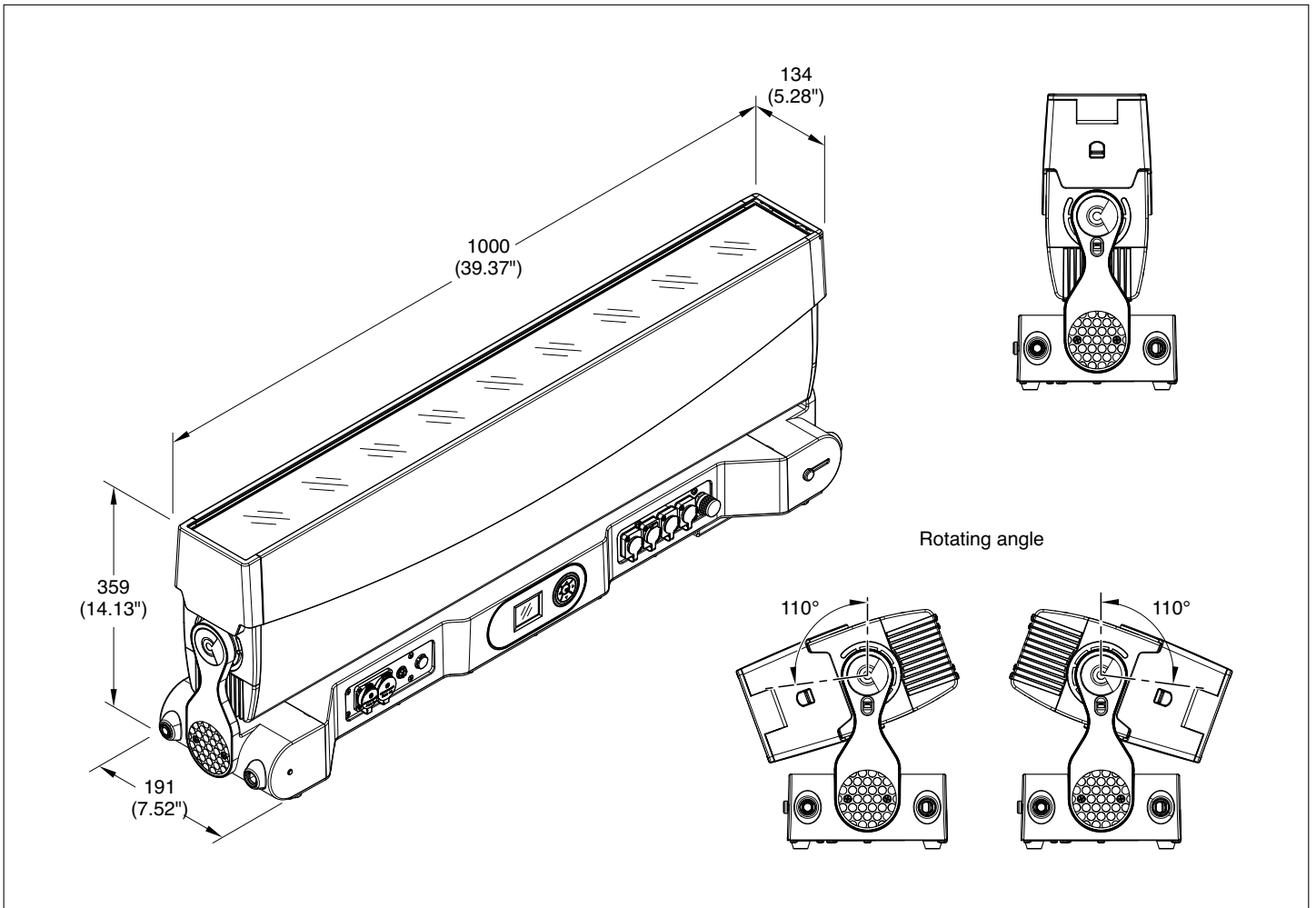

6. CAUSE AND SOLUTION OF PROBLEMS

THE PROJECTOR WILL NOT SWITCH ON			TROUBLE
ELECTRONICS NON-OPERATIONAL			
DEFECTIVE PROJECTION			
REDUCED LUMINOSITY			
	POSSIBLE CAUSES	CHECKS AND REMEDIES	
●	No power supply.	Check the power supply voltage.	
●	● LED burnt out or defective.	Call an authorised technician.	
	● Signal transmission cable faulty or disconnected.	Replace the cables.	
	● Incorrect addressing.	Check addresses (see instructions).	
	● Fault in the electronic circuits.	Call an authorised technician.	
	● Optic fault.	Call an authorised technician.	
	● ● Dust or grease deposits.	Clean (see instructions).	

