

ETC Setup Guide

Response Mk2 One-Port Gateway

This guide covers installation and basic setup of the Response Mk2 One-Port Gateway. You can configure additional software features using ETC Concert software. Reference the Help system built into Concert for more information. ETC Concert software can be found at etcconnect.com/Concert.

Overview

There are two versions of the One-Port Gateway: a wall-mount version and a portable version.

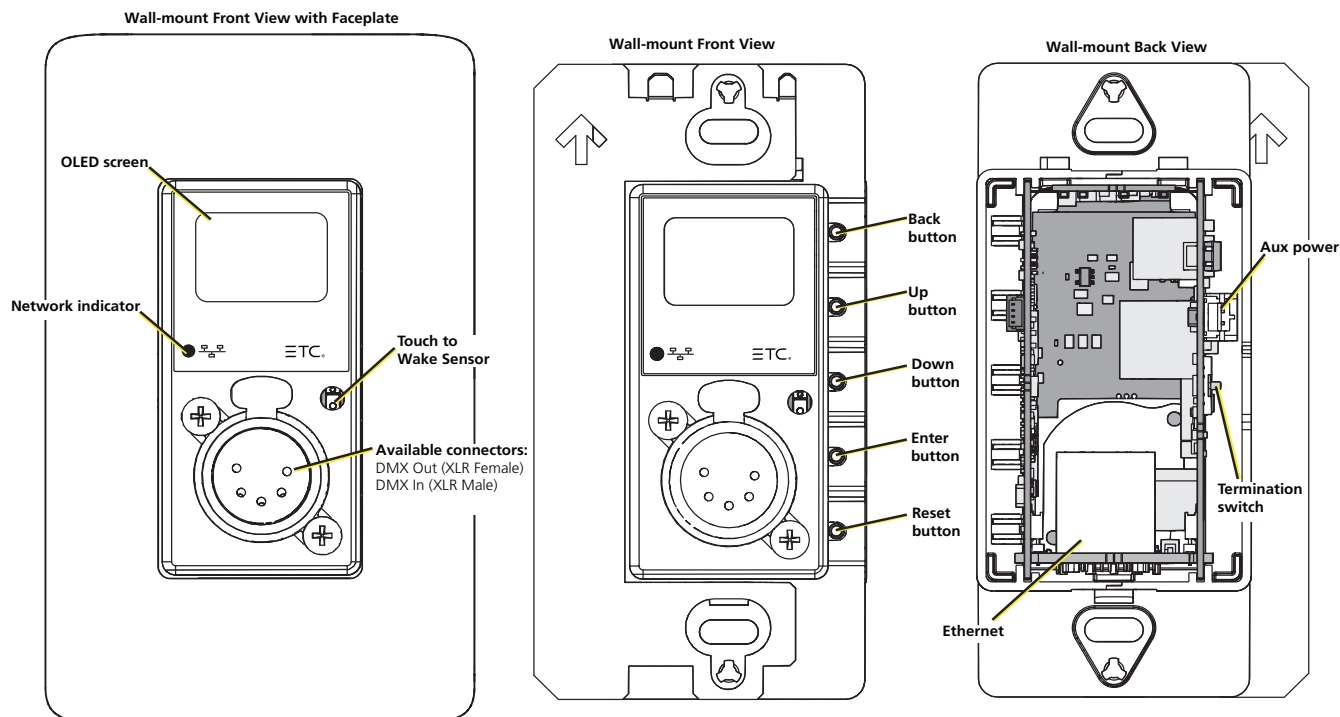

Action Buttons

- Up, Down, Back buttons - The Back button allows you to return to the previous menu or option and the Up and Down buttons navigate between menu options
- Enter - The Enter button allows you to advance to the next available menu option or commit a modified selection
- Reset - The Reset button provides a physical button to reset the gateway
- Touch to Wake Sensor - Cover the sensor with your hand to wake the display

LED Indicators

- Network - Solid green indicates network connection and blinking indicates network activity



ETC Setup Guide

One-Port Gateway

Electrical Specifications

The gateways are powered by either auxiliary power or Power over Ethernet (PoE).

- Auxiliary power input rated voltage of 12-24 VDC, 4 W Max, Polarity Independent
- 10/100Base-T, PoE power Class 1 (IEEE 802.3af)

For auxiliary power, the wall-mount gateway includes a red-and-black wire harness that connects to the supply conductors using two-position WAGO® connectors. The portable gateway uses a screw locking DC barrel connector for use with an external power supply (available separately).

If you supply both PoE and auxiliary power, the gateway defaults to using auxiliary. If auxiliary power is lost, the gateway will reboot and then begin using PoE.



Note: *If you are using an external power supply, it must be rated at a maximum of 15 watts.*

Connection Options

There are two different connector types available for the One-Port Gateway:

- DMX Out (five-pin female XLR)
- DMX In (five-pin male XLR)

The Response Mk2 Gateways send and receive DMX-512 control signals. DMX cables must be acceptable for DMX data transmission and connections should follow the standard pinouts per the charts below. The optional secondary data pair is not used by the Response Mk2 Gateways.

Pinouts

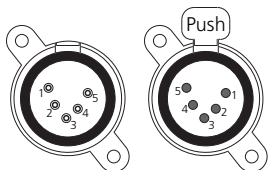

**DMX-512
Pinout for
five-pin XLR**

Pin	Use
1	Common (shield)
2	Data -
3	Data +
4	not connected
5	not connected

ETC Setup Guide

One-Port Gateway

DMX Termination

Termination is required for all DMX systems and belongs at the source (beginning) of a DMX line and at the last device physically connected in the line. A termination switch is located internally for each input/output and can be configured for DMX termination (IN), No termination (OFF) or RDM termination (OUT). By default, the DMX termination switch is set to the appropriate position based on the port type (Female XLR set to OUT and Male XLR set to IN).

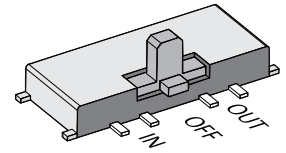

If you need to change the termination setting, perform the following steps:

1. Disconnect your gateway from all power supplies.
2. Remove the face plate and gateway from the back box or portable enclosure. If you are looking at the back of the gateway, the termination switch is on the exterior of the right side, beneath the auxiliary power connector.
3. Set the termination switch to the appropriate configuration.

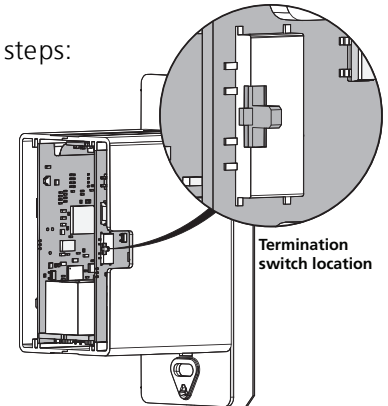

About RDM

Remote Device Management (RDM, ANSI E1.20) is a protocol enhancement to DMX-512 that allows bidirectional communication between a lighting system controller and attached RDM-compliant responder devices over a standard DMX line. This protocol allows configuration, status monitoring, and management of these devices.

An RDM Controller is the device that initiates communication with one or more RDM Responder devices. Examples of responders are RDM-enabled edge devices such as color scrollers, dimmers, moving lights, and LED fixtures. Compliant DMX-512 and DMX-512-A devices (non-RDM devices) are fully functional when RDM is present. The Response Mk2 Gateway supports up to 256 total RDM devices across its ports using standard DMX system design practices.



Note: *RDM is currently only supported on DMX Output ports.*

RDM Basics

By default, RDM discovery is not enabled on the gateway. To enable RDM on the gateway, use the ETC Concert software or the user interface on the front of the gateway. Please see the Concert online help files for more information on activating RDM on your gateways or see [Configure RDM Settings on page 7](#).

ETC Setup Guide

One-Port Gateway

Installation



Note: *Installation must follow all national and local codes for electrical equipment.*

The One-Port gateway is available in a wall-mount (for installation into a back box) and a portable (pipe, bar or truss mounted) version.

Wall-Mount

For surface-mount applications, ETC recommends using an ETC one-gang surface-mount back box (part# 1064A1037). For flush-mount applications, use a RACO #695 back box or equivalent (provided by others). The back box should be installed plumb and square for best results. Ensure that the box is clean and free of obstructions and that all wiring is installed correctly.

Connect Wiring

1. Pull all required wiring to the back box, including an Ethernet cable (Category 5e or better) and ground wire.
2. Terminate the Ethernet cable using the included kit (part# 4101A2003).
3. Connect the termination box to the gateway using the short male-to-male Ethernet cable included with the kit.
4. Using the provided WAGO® connector, connect the ground wire from the gateway to the incoming ground wire.

If you are using auxiliary power, perform the following additional steps:

1. Locate the 15 cm (6 in) red-and-black wire harness that came with your gateway.
2. Using the two-position WAGO connectors provided with your gateway, connect the red (positive) wire to one of them and the black (negative) wire to another.
3. Run the 24 VDC wires for your auxiliary power to the WAGO connectors.
4. Plug the two-pin connector on the end of the red-and-black wire harness into the power supply terminal connector on the PCB (located directly above the termination switch on the side of the gateway).

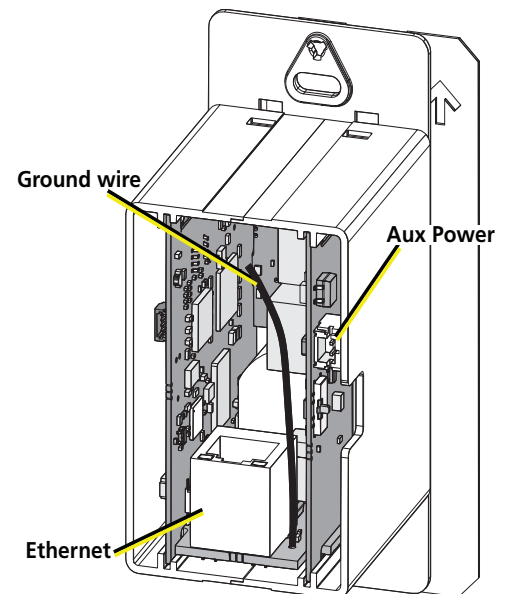

ETC Setup Guide

One-Port Gateway

Install into Back Box

1. Insert the gateway electronics and wiring into the back box.
2. Secure the gateway to the back box using the two screws provided.

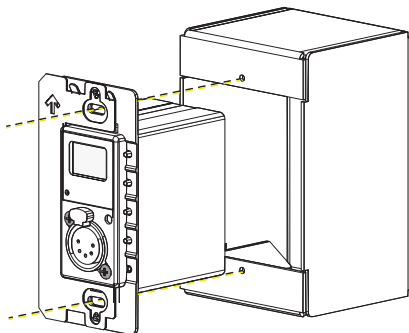

3. Align the top of the face plate to the station and angle the bottom approximately 20 degrees.
4. Hook the top of the face plate to the tabs on the top of gateway.
5. Swing the bottom of the face plate down until the magnets engage.

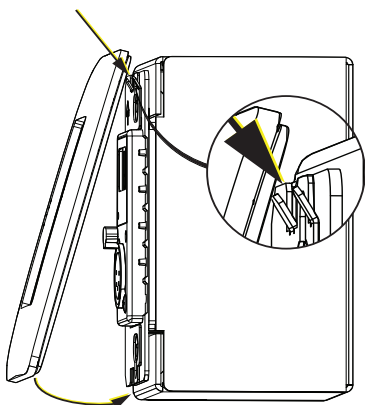

6. If the wall plate does not fully attach, wiggle the bottom of the plate until all the magnets are seated properly and the plate is secure.

Portable

The portable version of the gateway is designed for easy setup and can be mounted using the mounting bracket. The bracket contains holes that accommodate standard mounting hardware (available separately).

Once you have mounted the portable gateway, connect an RJ45 cable to the connector on the side of the unit. If you are not using PoE to power the gateway, connect a compatible power supply (available separately) to the barrel connector on the side of the gateway.

If you are not using either a grounded etherCON connector or DC power supply, use the ground point to connect the gateway to a suitable earth ground point.

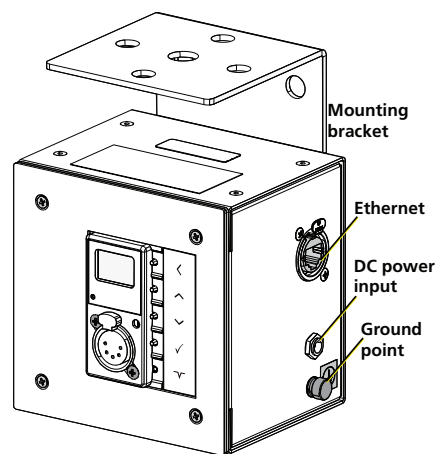

ETC Setup Guide

One-Port Gateway

Gateway User Interface and Configuration

The following sections provide information on basic tasks and configuration that you can perform from the user interface of the gateway. These tasks and additional configuration can all be performed using the ETC Concert application, available from etconnect.com.

Home Screen Information

The initial screen that your gateway displays is the Home screen, which provides the name of the gateway, the IP address and some basic port information. This image is what a typical home screen might look like on a four-port gateway, where the gateway name is DMX Gateway and IP address is 10.101.101.101.

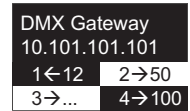

Additionally, the port information provides the following:

- Port 1 is *actively* (black background) *receiving* (left-facing arrow) DMX input and sending it to universe 12.
- Port 2 is *not actively* (white background) *outputting* (right-facing arrow) DMX from universe 50. If an inactive port is in data-loss behavior, such as holding, the port number is appended with an asterisk.
- Port 3 is not actively outputting DMX and *either has a universe above 999 or is split* . The ellipsis (...) indicates additional information that can be viewed from the About screen.
- Port 4 is actively outputting DMX from universe 100.
- Additionally, **DD** indicates a dimmer-doubled port, **AIP** indicates Advanced Input Patch, **^** indicates a port in downloader mode, and **X** indicates a disabled port.



Pressing the **Enter** button from the Home screen brings up three selectable menu options (**About**, **Setup**, **Operations**) from which you can access other information or configuration options.

If you receive a **User Interface Locked** message when accessing the **Setup** or **Operations** options, the gateway UI is locked. To unlock the UI, you must use the ETC Concert software.

View Device Information

To view information specific to your gateway, select the **About** menu option from the Home screen. From the About screen, you can select one of the following four options and then view the information specific to that option:

General	View Levels	Port Info	RDM Info
Ver: 1.0.0.12 FPGA: 1.0.0 Network	Port 1 Channel 1 State Active Level 127(50%)	Port 1 Mode Output U: 63999 Speed Max	Port 1 RDM Enabled Background Off Devices 128

Configure Network Settings

1. From the Home screen, select **Setup > Network**.
2. From the Mode screen, use the **Up** and **Down** buttons to select **Manual**, **Link Local** or **Automatic**.
 - **Automatic** attempts to automatically configure the IP Address, IP Subnet and IP Gateway for your device via DHCP.
 - If you select **Manual**, you must configure the IP Address, IP Subnet and IP Gateway screens and then select **OK** from the Apply/Reboot? screen.
 - If you select **Link Local**, the gateway self-assigns an IP address that is valid for the local network in the link-local address range. Select **OK** from the Apply/Reboot? screen.

ETC Setup Guide

One-Port Gateway

Configure Port Settings

1. From the Home screen, select **Setup > Ports**.
2. Use the **Enter** button to move from the menu options on the left to the values on the right side of the screen. Use the **Up** and **Down** buttons to change the values and press **Enter** again to confirm the change. Using these controls, configure the fields on screen:
 - **Port** - Select the port for which the following values apply:
 - **Mode** - Select the port mode. This can be set to Input, Output or Disabled.
 - **Universe** - Select the Universe of the port (1-63999).
 - **Speed** - Select the speed at which DMX is transmitted. This can be set to Slow, Medium, Fast, and Max.



Note: For detailed DMX speed timings, visit:
https://support.etconnect.com/ETC/FAQ/DMX_Speed.

Configure RDM Settings

1. From the Home screen, select **Setup > RDM**.
2. Use the **Enter** button to move from the menu options on the left to the values on the right side of the screen. Use the **Up** and **Down** buttons to change the values and press **Enter** again to confirm the change. Using these controls, configure the fields on screen:
 - **Port** - Select the port for which the following values apply:
 - **RDM** - Select whether RDM is enabled or disabled on the port.
 - **Background** - Select whether background discovery and polling of RDM is on or off.

Configure Data Loss Settings

1. From the Home screen, select **Setup > Data Loss**.
2. Use the **Enter** button to move from the menu options on the left to the values on the right side of the screen. Use the **Up** and **Down** buttons to change the values and press **Enter** again to confirm the change. Using these controls, configure the fields on screen:
 - **Port** - Select the port for which the following values apply:
 - **HLLF** - Select whether Hold Last Look Forever (HLLF) is on or off. Selecting **On** enables Hold Last Look Forever. Additional configuration options for hold last look are available in Concert.

ETC Setup Guide

One-Port Gateway

Restore Default Settings

To restore the factory defaults for your device, select the Operations menu from the home screen and choose the **Restore Defaults** option. This removes all network and master/backup information that is configured for your gateway but retains the gateway name.

```
Restore Defaults
All data
will be lost
OK?
```

Update Software

The recommended method of updating the gateway is through UpdaterAtor. The UpdaterAtor application is available for download at etconnect.com.

There is also an option to update the software from the gateway using a TFTP server like Conductor. To upgrade the software, select the Operations menu from the home screen and choose the **Update Software** option. If you do choose to update directly from the gateway, the bootloader runs and the latest software is downloaded from the server indicated by the <#. #.#.#> IP address on the Update Software screen. If you need to modify this IP address, you can configure it in the Concert application using the **Update Server** property.

```
Update Software
from server
10.101.50.60
OK?
```



Note: *Regardless of whether you update from UpdaterAtor or directly from the gateway, the device must be on the network.*

Test Port Output

You can test DMX outputs by selecting **Operations > Test Output** from the Home screen.



CAUTION: *Testing outputs drives all DMX levels to full. Use with caution in a show situation or when controlling high current devices.*

```
Port      1
State     -
Release All
```

This screen allows you to test the output for any port on your gateway.

- **Port** - Press the **Enter** button to select and then use the **Up** and **Down** buttons to cycle through the ports of your gateway. Press **Enter** again to select the port.
- **State** - Press **Enter** to select and then use the **Up** and **Down** buttons to cycle through the test state options. If the port is an input, this field displays either Input or Disabled. If the port is an output, you can select either Released (--), Full or All Zero.
- **Release All** - Press the **Enter** button to release the test state on all ports. Once outputs are set into a test state they can be released from this menu, from Concert or by rebooting the gateway.



Note: *This product uses licensed software provided by third parties. Please visit <http://www.etconnect.com/licenses/> for licensing information.*
