

Rail-Enclosures on TS35: maximum load

Requirement:

- correct assembly of the DIN rail
- Static loading / no vibrations

By use of DIN rail bracket:

- correct assembly of the DIN rail bracket to the enclosure

The maximum possible load can be found in the following table:

model	Load Mmax (Ncm)
TSH 35	400 Ncm
TSH 35-2 1)	80 Ncm
TSH 35-2 2)	300 Ncm
TSH 35 AL-50	800 Ncm
TSH 35 AL-100	1000 Ncm
CombiNorm Classic	400 Ncm
CombiNorm Compact	400 Ncm
CombiNorm Connect	400 Ncm
CombiNorm Control	200 Ncm
CombiRail	400 Ncm
AluRail $L \leq 100\text{mm}$	800 Ncm
AluRail $L \geq 100\text{mm}$	1000 Ncm
CC 500 TS	500 Ncm

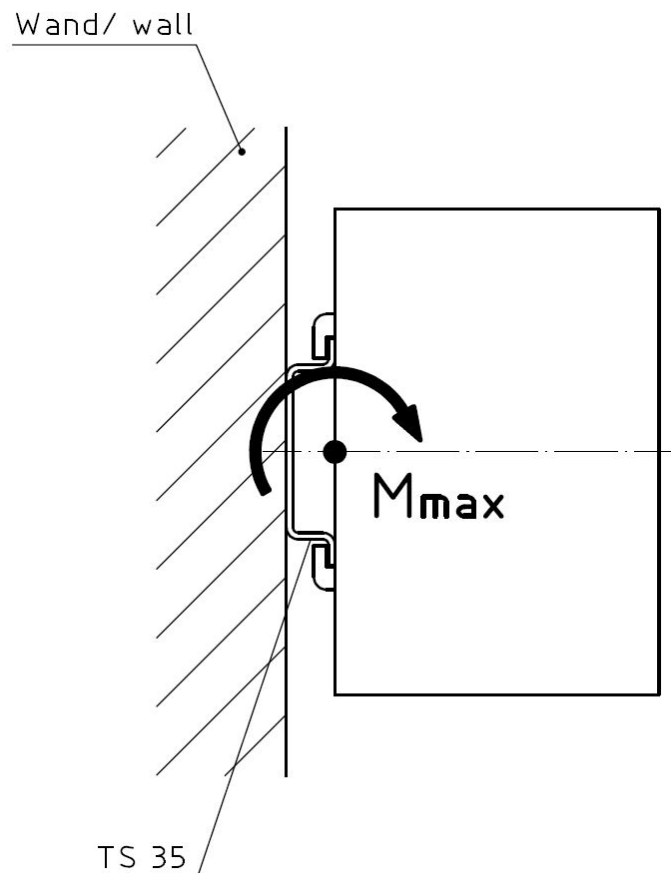

- 1) Screw fitting from inside
- 2) Screw fitting from outside

Please note!

All technical information stated here is provided to the best of our knowledge, but nonetheless in no way exempts the user from the duty to verify the suitability of the product for the intended application.